



MIAMI-DADE COUNTY, FLORIDA
METRO-DADE FLAGLER BUILDING
140 WEST FLAGLER STREET, SUITE 1603
MIAMI, FLORIDA 33130-1563
(305) 375-2901 FAX (305) 372-6339
www.miamidade.gov/buildingcode

BUILDING CODE COMPLIANCE OFFICE (BCCO)
PRODUCT CONTROL DIVISION
NOTICE OF ACCEPTANCE (NOA)

T.M. Window & Door LLC
601 N.W. 12th Ave.
Pompano Beach, FL 33609

SCOPE:

This NOA is being issued under the applicable rules and regulations governing the use of construction materials. The documentation submitted has been reviewed by Miami-Dade County Product Control Division and accepted by the Board of Rules and Appeals (BORA) to be used in Miami Dade County and other areas where allowed by the Authority Having Jurisdiction (AHJ).

This NOA shall not be valid after the expiration date stated below. The Miami-Dade County Product Control Division (In Miami Dade County) and/or the AHJ (in areas other than Miami Dade County) reserve the right to have this product or material tested for quality assurance purposes. If this product or material fails to perform in the accepted manner, the manufacturer will incur the expense of such testing and the AHJ may immediately revoke, modify, or suspend the use of such product or material within their jurisdiction. BORA reserves the right to revoke this acceptance, if it is determined by Miami-Dade County Product Control Division that this product or material fails to meet the requirements of the applicable building code.

This product is approved as described herein, and has been designed to comply with the Florida Building Code, including the High Velocity Hurricane Zone.

DESCRIPTION: Series "515" Outswing Aluminum Casement Window – L.M.I.

APPROVAL DOCUMENT: Drawing No. **W06-30**, titled "Series 515 Aluminum Casement Window (L.M.I.)", sheets 1 through 7 of 7, dated 04/14/06 with revision B dated 01/11/08, prepared by Al-Farooq Corporation, signed and sealed by Humayoun Farooq, P.E., bearing the Miami-Dade County Product Control Revision stamp with the Notice of Acceptance number and expiration date by the Miami-Dade County Product Control Division.

MISSILE IMPACT RATING: Large and Small Missile Impact Resistant

LABELING: Each unit shall bear a permanent label with the manufacturer's name or logo, city, state and following statement: "Miami-Dade County Product Control Approved", unless otherwise noted herein.

RENEWAL of this NOA shall be considered after a renewal application has been filed and there has been no change in the applicable building code negatively affecting the performance of this product.

TERMINATION of this NOA will occur after the expiration date or if there has been a revision or change in the materials, use, and/or manufacture of the product or process. Misuse of this NOA as an endorsement of any product, for sales, advertising or any other purposes shall automatically terminate this NOA. Failure to comply with any section of this NOA shall be cause for termination and removal of NOA.

ADVERTISEMENT: The NOA number preceded by the words Miami-Dade County, Florida, and followed by the expiration date may be displayed in advertising literature. If any portion of the NOA is displayed, then it shall be done in its entirety.

INSPECTION: A copy of this entire NOA shall be provided to the user by the manufacturer or its distributors and shall be available for inspection at the job site at the request of the Building Official. This NOA **revises and renews NOA # 06-0614.03** and consists of this page 1 and evidence page E-1, as well as approval document mentioned above.

The submitted documentation was reviewed by **Manuel Perez, P.E.**



NOA No. 08-0506.11
Expiration Date: May 01, 2013
Approval Date: June 05, 2008
Page 1

NOTICE OF ACCEPTANCE: EVIDENCE SUBMITTED

A. DRAWINGS

1. Manufacturer's die drawings and sections.
2. Drawing No **W06-30**, Sheets 1 through 7 of 7, titled "Series 515 Outswing Aluminum Casement Window (L.M.I.)", dated 04/14/06 with revision B dated 01/11/08, prepared by Al-Farooq Corporation, signed and sealed by Humayoun Farooq, P.E.

B. TESTS

1. Test reports on: 1) Air Infiltration Test, per FBC, TAS 202-94
2) Uniform Static Air Pressure Test, Loading per FBC TAS 202-94
3) Water Resistance Test, per FBC, TAS 202-94
4) Large Missile Impact Test per FBC, TAS 201-94
5) Cyclic Wind Pressure Loading per FBC, TAS 203-94
6) Forced Entry Test, per FBC 2411 3.2.1, TAS 202-94
along with marked-up drawings and installation diagram of a series 515 outswing aluminum casement window, prepared by Fenestration Testing Laboratory, Inc., Test Report No. **FTL-5404**, dated 11/16/07, signed and sealed by Carlos S. Rionda, P.E.
2. Test reports on: 1) Uniform Static Air Pressure Test, Loading per FBC TAS 202-94
2) Large Missile Impact Test per FBC, TAS 201-94
3) Cyclic Wind Pressure Loading per FBC, TAS 203-94
along with marked-up drawings and installation diagram of a series 515 outswing aluminum casement window, prepared by Fenestration Testing Laboratory, Inc., Test Report No. **FTL-4891**, dated 04/13/06, signed and sealed by Edmundo Largaespada, P.E.
(Submitted under NOA# 06-0614.03)
3. Test reports on: 1) Large Missile Impact Test per FBC, TAS 201-94
2) Cyclic Wind Pressure Loading per FBC, TAS 203-94
along with marked-up drawings and installation diagram of a series 515 outswing aluminum casement window, prepared by Fenestration Testing Laboratory, Inc., Test Report No. **FTL-4890**, dated 04/13/06, signed and sealed by Edmundo Largaespada, P.E.
(Submitted under NOA# 06-0614.03)
4. Test reports on: 1) Uniform Static Air Pressure Test, Loading per FBC, TAS 20294
2) Large Missile Impact Test per FBC, TAS 201-94
3) Cyclic Wind Pressure Loading per FBC, TAS 203-94
along with installation diagram of an aluminum casement window, prepared by American Test Lab of South Florida, Test Report No. **ATL 0806.01-02** dated 09/24/02, signed and sealed by William R. Mehner, P.E.
(Submitted under NOA# 01-1129.03)

Manuel Perez, P.E.
Product Control Examiner
NOA No. 08-0506.11

Expiration Date: May 01, 2013
Approval Date: June 05, 2008

NOTICE OF ACCEPTANCE: EVIDENCE SUBMITTED

5. Test reports on: 1) Air Infiltration Test, per FBC, TAS 202-94
2) Uniform Static Air Pressure Test, Loading per FBC, TAS 20294
3) Water Resistance Test, per FBC, TAS 202-94
4) Large Missile Impact Test per FBC, TAS 201-94
5) Small Missile Impact Test per FBC, TAS 201-94 (FTL2770)
6) Cyclic Wind Pressure Loading per FBC, TAS 203-94
7) Forced Entry Test, per FBC 2411 3.2.1 and TAS 202-94
along with marked-up drawings and installation diagram of an aluminum casement window, prepared by Fenestration Testing Laboratory, Inc., Test Report No. FTL-2770, dated 3/30/01, signed and sealed by Luis Antonio Figueredo, P. E.
(Submitted under NOA# 01-1129.03)

C. CALCULATIONS

1. Anchor verification calculations and structural analysis, complying with FBC-2004, prepared by Al-Farooq Corporation, dated 01/26/08, signed and sealed by Humayoun Farooq, P.E. **Complies with ASTM E1300-02**

D. QUALITY ASSURANCE

1. Miami Dade Building Code Compliance Office (BCCO).

E. MATERIAL CERTIFICATIONS

1. Notice of Acceptance No. **03-0225.10** issued to Glasslam NGI Inc. for their “**Safety-Plus II - Laminated Glass**” dated 08/07/03, expiring on 08/07/08.
2. Notice of Acceptance No. **06-0216.06** issued to Solutia Inc. for their “**Saflex III G Clear or colored interlayer**” dated 05/04/06, expiring on 05/21/11.
3. Notice of Acceptance No. **03-1117.05** issued to Surface Specialties, Inc. for their “**Uvekols – Liq. Resin to adhere Glass**” dated 01/29/2004, expiring on 02/08/2009.
4. Notice of Acceptance No. **03-0225.10** issued to Glasslam NGI Inc. for their “**Safety-Plus II - Laminated Glass**” dated 08/07/03, expiring on 08/07/08.

F. STATEMENTS

1. Statement letter of conformance, dated January 16, 2008, signed and sealed by Humayoun Farooq, P.E.
2. Statement letter of no financial interest, dated January 16, 2008, signed and sealed by Humayoun Farooq, P.E.
3. Laboratory compliance letter for Test Report no. **FTL-5404**, issued by Hurricane Test Laboratory, Inc., dated December 19, 2007, signed and sealed by Carlos S. Rionda, P.E.

G. OTHER

1. Notice of Acceptance No. **06-0614.03**, issued to T.M. Window and Door for their Series “515” Aluminum Outswing Casement Window - LM Impact, approved on 11/08/06 and expiring on 05/01/08.

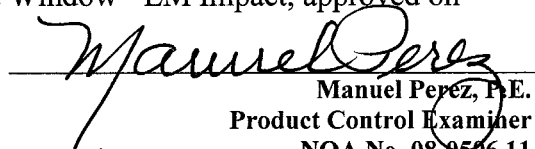
Manuel Perez, P.E.
Product Control Examiner
NOA No. 08-0506.11
Expiration Date: May 01, 2013
Approval Date: June 05, 2008

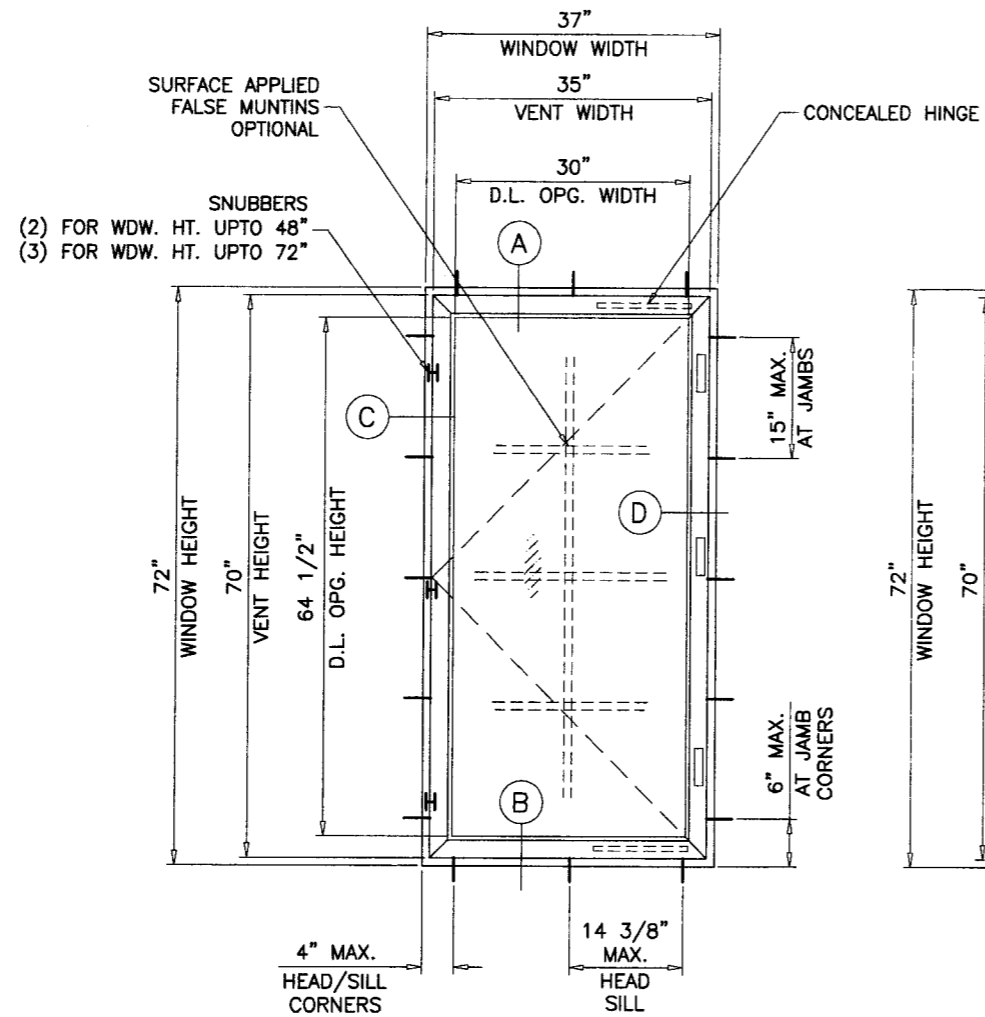

SINGLE VENT WDW.

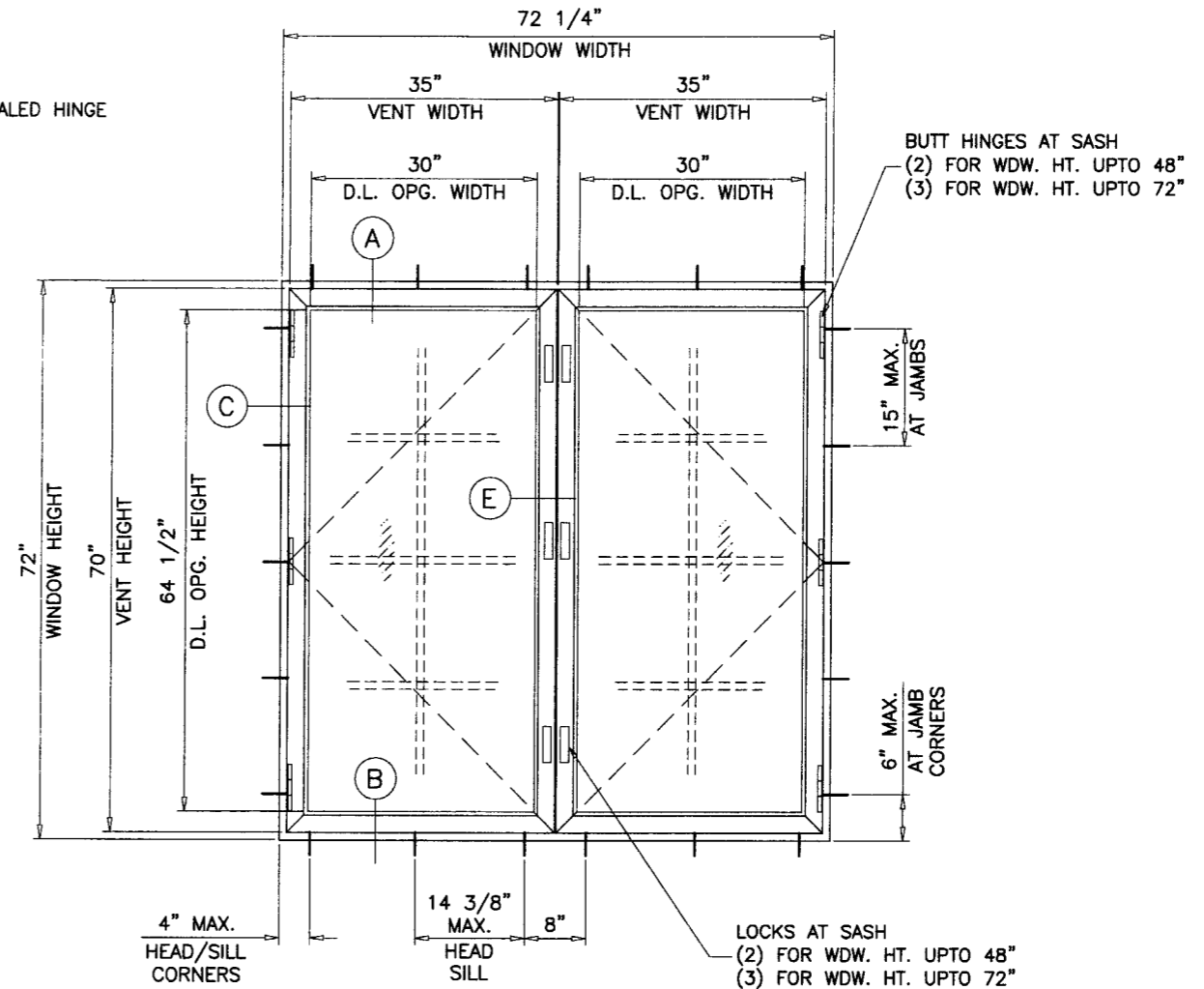

DUAL VENT WDW.

THESE WINDOWS ARE RATED FOR LARGE MISSILE IMPACT. SHUTTERS ARE NOT REQUIRED.

SERIES 515 ALUMINUM CASEMENT WINDOW

DESIGN LOAD RATINGS FOR THESE WINDOWS TO BE AS PER CHARTS SHOWN ON SHEET 2.

APPROVAL APPLIES TO SINGLE CASEMENT WINDOWS, ALSO COMBINATIONS OF CASMT/CASMT OR CASMT WITH OTHER WINDOW TYPES IN MODULES OF TWO OR MORE WINDOWS USING MIAMI-DADE COUNTY APPROVED MULLIONS IN BETWEEN. LOWER DESIGN PRESSURE FROM WINDOWS OR MULLION APPROVAL WILL APPLY TO ENTIRE SYSTEM.

THIS PRODUCT HAS BEEN DESIGNED AND TESTED TO COMPLY WITH THE REQUIREMENTS OF THE FLORIDA BUILDING CODE 2004 EDITION INCLUDING HIGH VELOCITY HURRICANE ZONE (HVHZ).

WOOD BUCKS BY OTHERS, MUST BE ANCHORED PROPERLY TO TRANSFER LOADS TO THE STRUCTURE.

ANCHORS SHALL BE AS LISTED, SPACED AS SHOWN ON DETAILS, ANCHORS EMBEDMENT TO BASE MATERIAL SHALL BE BEYOND WALL DRESSING OR STUCCO.

ANCHORING OR LOADING CONDITIONS NOT SHOWN IN THESE DETAILS ARE NOT PART OF THIS APPROVAL.

A LOAD DURATION INCREASE IN ALLOWABLE STRESS IS USED IN DESIGN OF ANCHORS INTO WOOD ONLY.

MATERIALS INCLUDING BUT NOT LIMITED TO STEEL/METAL SCREWS, THAT COME INTO CONTACT WITH OTHER DISSIMILAR MATERIALS SHALL MEET THE REQUIREMENTS OF 2004 FLORIDA BLDG. CODE SECTION 2003.8.4.

D.L. OPENINGS

DLO HT. = WDW. HT - 7.5"
 DLO W. (SINGLE VENT) = WDW. W - 7"
 DLO W. (DUAL VENT) = WDW. W/2 - 6.125"

**LAMINATED GLASS
 LARGE MISSILE IMPACT**

Engr. DR. HUMAYOUN FAROOQ
 STRUCTURES
 FLA. PE # 16557
 C.A.N. 3538

JAN 25 2008

PRODUCT REVISED
 as complying with the Florida
 Building Code
 Acceptance No. **08-0506.11**
 Expiration Date **MAY 1, 2013**
 By *Manuel Perez*
 Miami Dade Product Control
 Division

afC
AL-FAROOQ CORPORATION
 ENGINEERS & PRODUCT DEVELOPMENT
 1235 S.W. 87 AVE
 MIAMI, FLORIDA 33174
 TEL. (305) 264-8100 FAX. (305) 262-6978
 COMP-ANL\W06-30TMW

SERIES 515 ALUMINUM CASEMENT WINDOW (L.M.I.)
TM WINDOW AND DOOR
 601 N.W. 12TH AVE.
 POMPANO BEACH, FL. 33069
 TEL. (954) 781-4430 FAX. (954) 781-5078

no	date	by	description
A	10.11.06	REV. PER BCCO COMMENTS	
B	01.11.08	GLASS & HARDWARE OPTIONS ADD.	

revisions:
 date: 04-14-06
 scale: 1/2" = 1"
 dr. by: HAMID
 chk. by:
 drawing no. **W06-30**
 sheet 1 of 7

* DESIGN LOAD CAPACITY - PSF FOR (X) SIZES					
WINDOW DIMS.		GLASS TYPES 'A' & 'C'		GLASS TYPES 'B', 'D' & 'E'	
WIDTH	HEIGHT	EXT.(+)	INT.(-)	EXT.(+)	INT.(-)
19-1/8"	26" (2)	62.0	62.0	80.0	80.0
26-1/2"		62.0	62.0	80.0	80.0
37"		62.0	62.0	80.0	80.0
19-1/8"	38-3/8" (3)	62.0	62.0	80.0	80.0
26-1/2"		62.0	62.0	80.0	80.0
37"		62.0	62.0	80.0	80.0
19-1/8"	50-5/8" (4)	62.0	62.0	80.0	80.0
26-1/2"		62.0	62.0	80.0	80.0
37"		62.0	62.0	80.0	80.0
19-1/8"	63" (5)	62.0	62.0	80.0	80.0
26-1/2"		62.0	62.0	80.0	80.0
37"		62.0	62.0	80.0	80.0
19-1/8"	74-1/4" (6)	62.0	62.0	80.0	80.0
26-1/2"		62.0	62.0	80.0	80.0
30"	74-1/4"(6)	62.0	62.0	80.0	80.0
18"	24" (2)	62.0	62.0	80.0	80.0
24"		62.0	62.0	80.0	80.0
30"		62.0	62.0	80.0	80.0
36"		62.0	62.0	80.0	80.0
18"	36" (3)	62.0	62.0	80.0	80.0
24"		62.0	62.0	80.0	80.0
30"		62.0	62.0	80.0	80.0
36"		62.0	62.0	80.0	80.0
18"	48" (4)	62.0	62.0	80.0	80.0
24"		62.0	62.0	80.0	80.0
30"		62.0	62.0	80.0	80.0
36"		62.0	62.0	80.0	80.0
18"	60" (5)	62.0	62.0	80.0	80.0
24"		62.0	62.0	80.0	80.0
30"		62.0	62.0	80.0	80.0
36"		62.0	62.0	80.0	80.0
18"	63" (5)	62.0	62.0	80.0	80.0
24"		62.0	62.0	80.0	80.0
30"		62.0	62.0	80.0	80.0
36"		62.0	62.0	80.0	80.0
18"	72" (6)	62.0	62.0	80.0	80.0
24"		62.0	62.0	80.0	80.0
30"		62.0	62.0	80.0	80.0
36"		62.0	62.0	80.0	80.0
37"	72" (6)	62.0	62.0	80.0	80.0

() = NO. OF ANCHORS PER JAMB

DESIGN LOAD CAPACITY - PSF FOR (XX) SIZES					
WINDOW DIMS.		GLASS TYPES 'A' & 'C'		GLASS TYPES 'B', 'D' & 'E'	
WIDTH	HEIGHT	EXT.(+)	INT.(-)	EXT.(+)	INT.(-)
26-1/2"	26" (2)	62.0	62.0	80.0	80.0
37"		62.0	62.0	80.0	80.0
53-1/8"		62.0	62.0	80.0	80.0
74"		62.0	62.0	80.0	80.0
26-1/2"	38-3/8" (3)	62.0	62.0	80.0	80.0
37"		62.0	62.0	80.0	80.0
53-1/8"		62.0	62.0	80.0	80.0
74"	50-5/8" (4)	62.0	62.0	80.0	80.0
26-1/2"		62.0	62.0	80.0	80.0
37"		62.0	62.0	80.0	80.0
53-1/8"	63" (5)	62.0	62.0	80.0	80.0
74"		62.0	62.0	80.0	80.0
26-1/2"		62.0	62.0	80.0	80.0
37"	72" (6)	62.0	62.0	80.0	80.0
53-1/8"		45.5	45.5	45.5	45.5
74"		32.7	32.7	32.7	32.7
24"	24" (2)	62.0	62.0	80.0	80.0
36"		62.0	62.0	80.0	80.0
48"		62.0	62.0	80.0	80.0
60"		62.0	62.0	80.0	80.0
72"	36" (3)	62.0	62.0	80.0	80.0
24"		62.0	62.0	80.0	80.0
36"		62.0	62.0	80.0	80.0
48"		62.0	62.0	80.0	80.0
60"	48" (4)	62.0	62.0	80.0	80.0
72"		62.0	62.0	80.0	80.0
24"		62.0	62.0	80.0	80.0
36"		62.0	62.0	80.0	80.0
48"	60" (5)	62.0	62.0	80.0	80.0
60"		62.0	62.0	80.0	80.0
72"		62.0	62.0	80.0	80.0
24"		62.0	62.0	80.0	80.0
36"	63" (5)	62.0	62.0	80.0	80.0
48"		62.0	62.0	75.2	75.2
60"		60.2	60.2	60.2	60.2
72"		50.1	50.1	50.1	50.1
24"	72" (6)	62.0	62.0	80.0	80.0
36"		62.0	62.0	67.2	67.2
48"		50.4	50.4	50.4	50.4
60"		40.3	40.3	40.3	40.3
72"		33.6	33.6	33.6	33.6

() = NO. OF ANCHORS PER JAMB

NOTE:
GLASS CAPACITIES ON THIS SHEET ARE
BASED ON ASTM E1300-02 (3 SEC. GUSTS).



AL-FAROOQ CORPORATION
ENGINEERS & PRODUCT DEVELOPMENT
1235 S.W. 87 AVE
MIAMI, FLORIDA 33174
TEL. (305) 264-8100 FAX. (305) 262-6978
COMP-ANL W06-30TMW

SERIES 515 ALUMINUM CASEMENT WINDOW (L.M.I.)
TM WINDOW AND DOOR
601 N.W. 12TH AVE.
POMPANO BEACH, FL. 33069
TEL. (954) 781-4430 FAX. (954) 781-5078

no	date	description
A	10.11.06	REV. PER BCCO COMMENTS
B	01.11.08	GLASS & HARDWARE OPTIONS ADD.

date: 04-14-06
scale: 1/2" = 1"
dr. by: HAMID
chk. by:

Engr. DR. HUMAYOUN FAROOQ
STRUCTURES
FLA. PE # 16557
C.A.N. 3538
JAN 25 2008

PRODUCT REVISED
as complying with the Florida
Building Code
Acceptance No. 08-0506.11
Expiration Date MAY 1 2013
By Muhammad Farooq
Miami/Dade Product Control
Division

drawing no.
W06-30
sheet 2 of 7

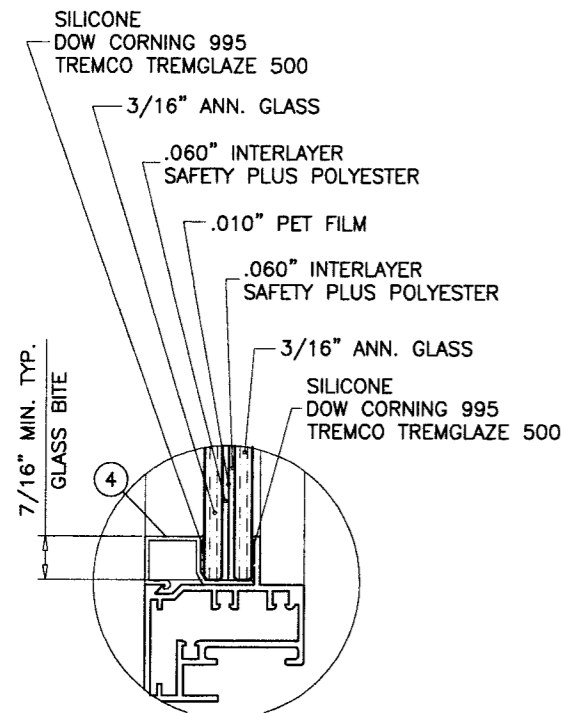

GLASS TYPE 'A'

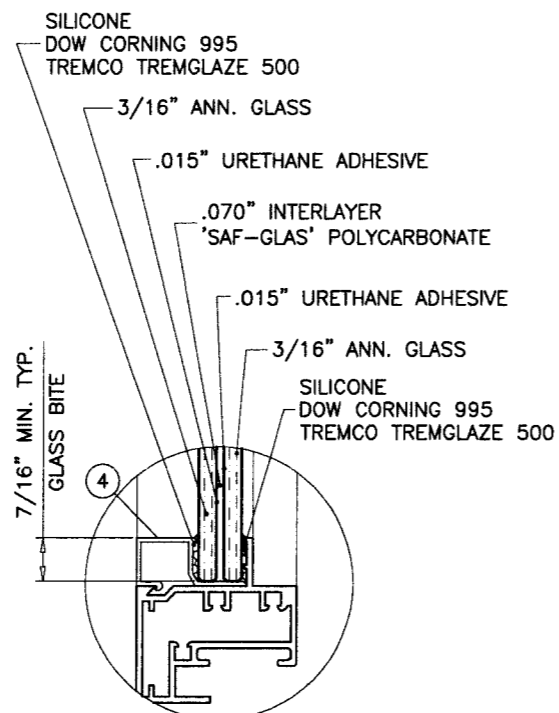

GLASS TYPE 'B'

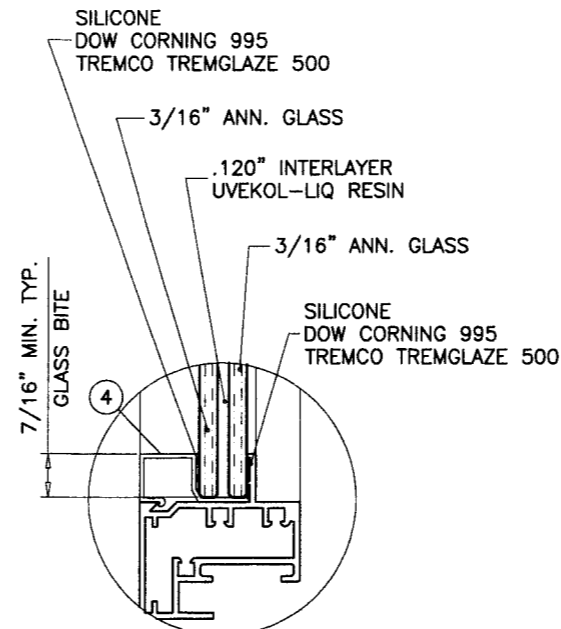

GLASS TYPE 'C'

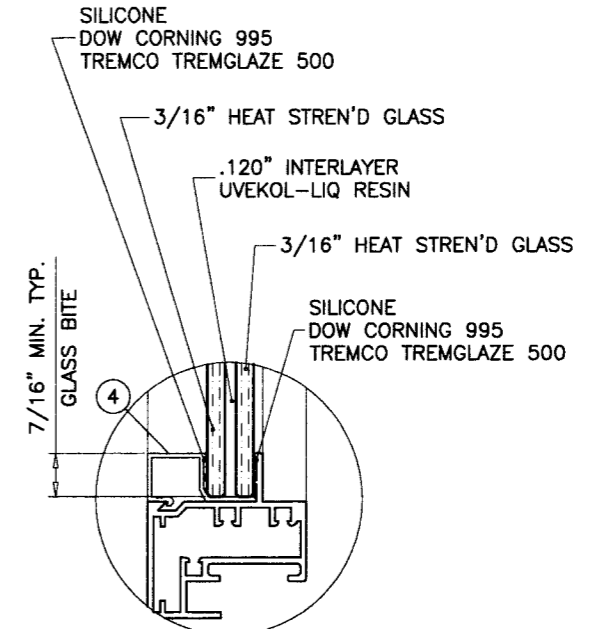

GLASS TYPE 'D'

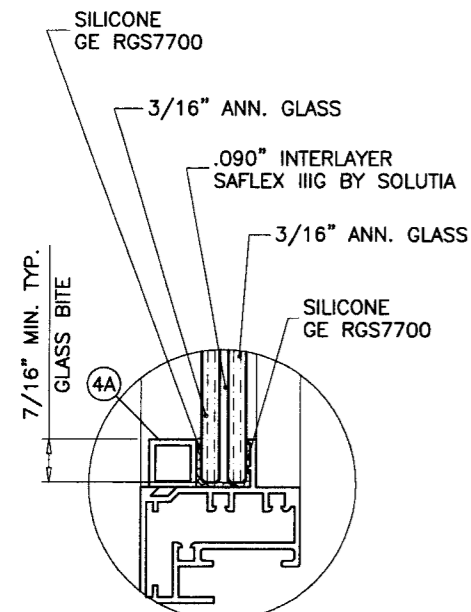

GLASS TYPE 'E'

GLAZING OPTIONS

Engr. DR. HUMAYOUN FAROOQ
STRUCTURES
FLA. PE # 16557
C.A.N. 3538

JAN 25 2008

PRODUCT REVISED
as complying with the Florida
Building Code
Acceptance No. 08-0506.11
Expiration Date MAY 1 2013

By: *Manuel Perez*
Miami Made Product Control
Division

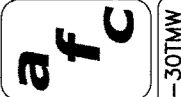

AL-FAROOQ CORPORATION
ENGINEERS & PRODUCT DEVELOPMENT
1235 S.W. 87 AVE
MIAMI, FLORIDA 33174
TEL. (305) 264-8100 FAX. (305) 262-6978
COMP-ANL\W06-30TAW

SERIES 515 ALUMINUM CASEMENT WINDOW (L.M.I.)

TM WINDOW AND DOOR
601 N.W. 12TH AVE.
POMPANO BEACH, FL. 33069
TEL. (954) 781-4430 FAX. (954) 781-5078

no	date	by	description
A	10.11.06	REV. PER BCCO COMMENTS	
B	01.11.08	GLASS & HARDWARE OPTIONS ADD.	

date: 04-14-06
scale: 1/2" = 1"
dr. by: HAMID
chk. by:

drawing no.
W06-30

sheet 3 of 7

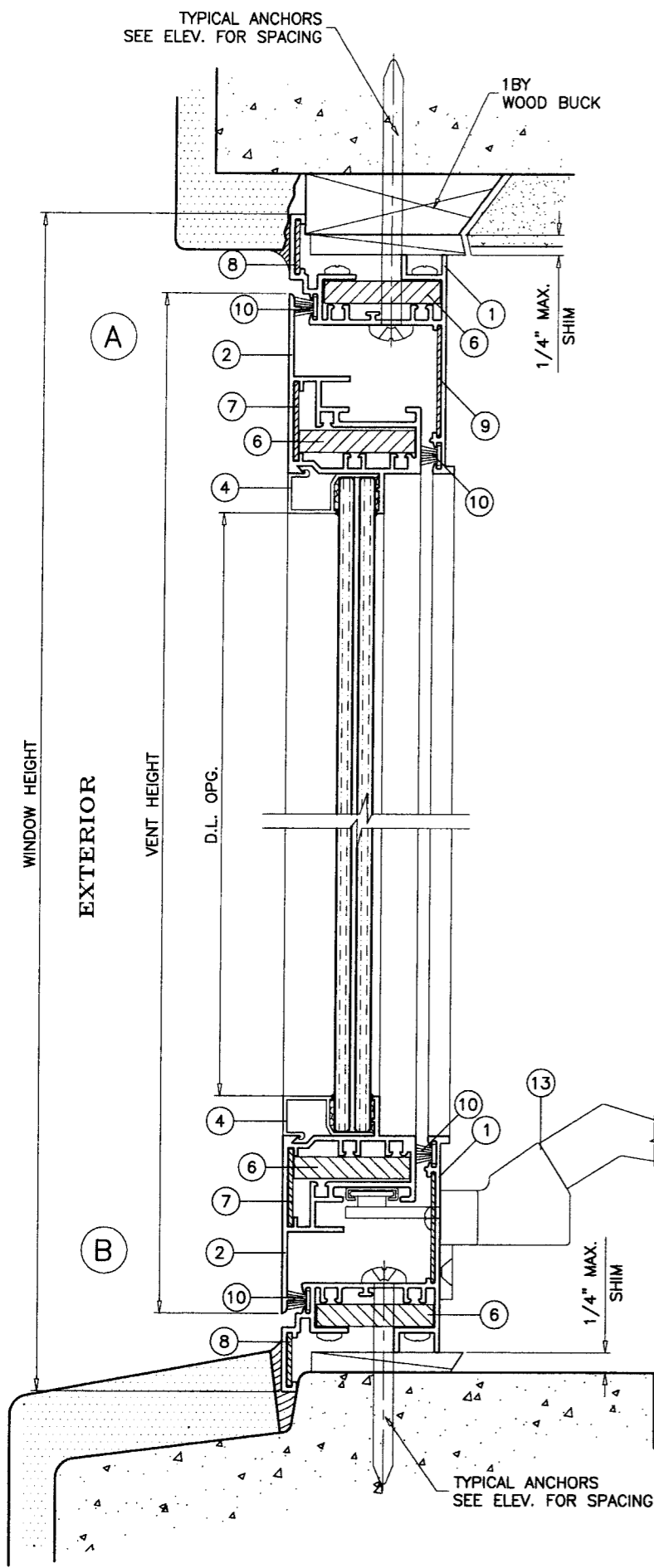

BUTT HINGE OPTION

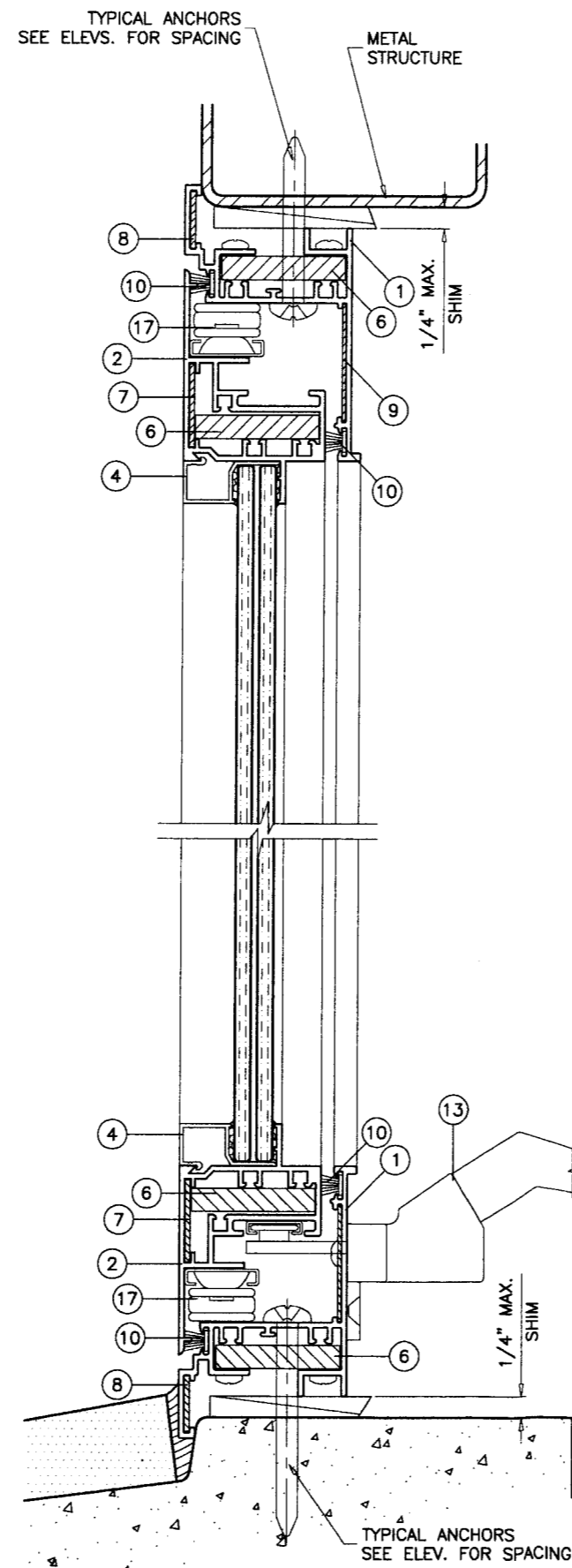

CONCEALED HINGE OPTION

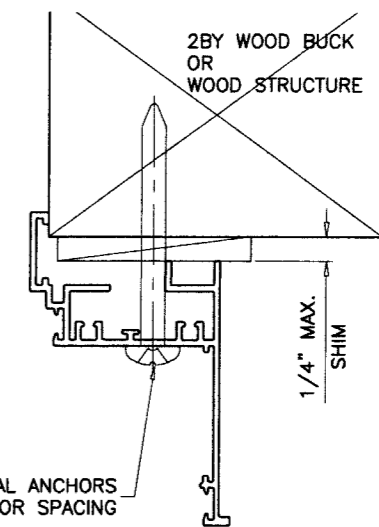
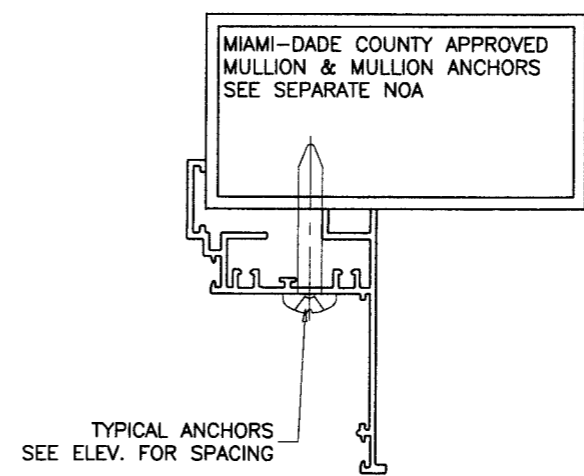

WOOD BUCKS AND METAL STRUCTURE NOT BY TM WINDOWS MUST SUSTAIN LOADS IMPOSED BY GLAZING SYSTEM AND TRANSFER THEM TO THE BUILDING STRUCTURE.

TYPICAL ANCHORS: SEE ELEV. FOR SPACING
1/4" TAPCONS
 INTO 2BY WOOD BUCKS OR WOOD STRUCTURES
 1-3/8" MIN. PENETRATION INTO WOOD
 THRU 1BY BUCKS INTO CONC. OR MASONRY
 1-1/4" MIN. EMBED INTO CONC. OR MASONRY
 DIRECTLY INTO CONC. OR MASONRY
 1-1/4" MIN. EMBED INTO CONC. OR MASONRY
#14 SMS OR SELF DRILLING SCREWS
 INTO METAL STRUCTURES
 STEEL : 12 GA. MIN. (Fy = 36 KSI MIN.)
 ALUMINUM : 1/8" THK. MIN. (6063-T5 MIN.)
 (STEEL IN CONTACT WITH ALUMINUM TO BE PLATED OR PAINTED)

#14 SMS OR SELF DRILLING SCREWS
 INTO DADE COUNTY APPROVED MULLIONS (MIN. THK. = .125")
 (NO SHIM SPACE)

TYPICAL EDGE DISTANCE
 INTO CONCRETE AND MASONRY = 1-1/2" MIN.
 INTO WOOD STRUCTURE = 1" MIN.
 INTO METAL STRUCTURE = 1/2" MIN.

SEALANTS:
 ALL JOINTS AND FRAME CONNECTIONS SEALED WITH SILICONE OR ACRYLIC SEALANT.

Engr: DR. HUMAYOUN FAROOQ
 STRUCTURES
 FLA. PE # 16557
 C.A.N. 3538

PRODUCT REVISED
 as complying with the Florida
 Building Code
 Acceptance No. 08-0506.11
 Expiration Date MAY 1, 2013
 By: *Manuel Perez*
 Miami Dade Product Control
 Division

JAN 25 2008

af c
AL-FAROOQ CORPORATION
 ENGINEERS & PRODUCT DEVELOPMENT
 1235 S.W. 87 AVE
 MIAMI, FLORIDA 33174
 TEL. (305) 264-8100 FAX. (305) 262-6978
 COMP-ANL\W06-30TMW

SERIES 515 ALUMINUM CASEMENT WINDOW (L.M.I.)
TM WINDOW AND DOOR
 601 N.W. 12TH AVE.
 POMPANO BEACH, FL. 33069
 TEL. (954) 781-4430 FAX. (954) 781-5078

no	date	by	description
A	10.11.06	REV. PER BCCO	COMMENTS
B	01.11.08	GLASS & HARDWARE	OPTIONS ADD.

revisions:
 date: 04-14-06
 scale: 1/2" = 1"
 dr. by: HAMID
 chk. by:

drawing no.
W06-30
 sheet 4 of 7

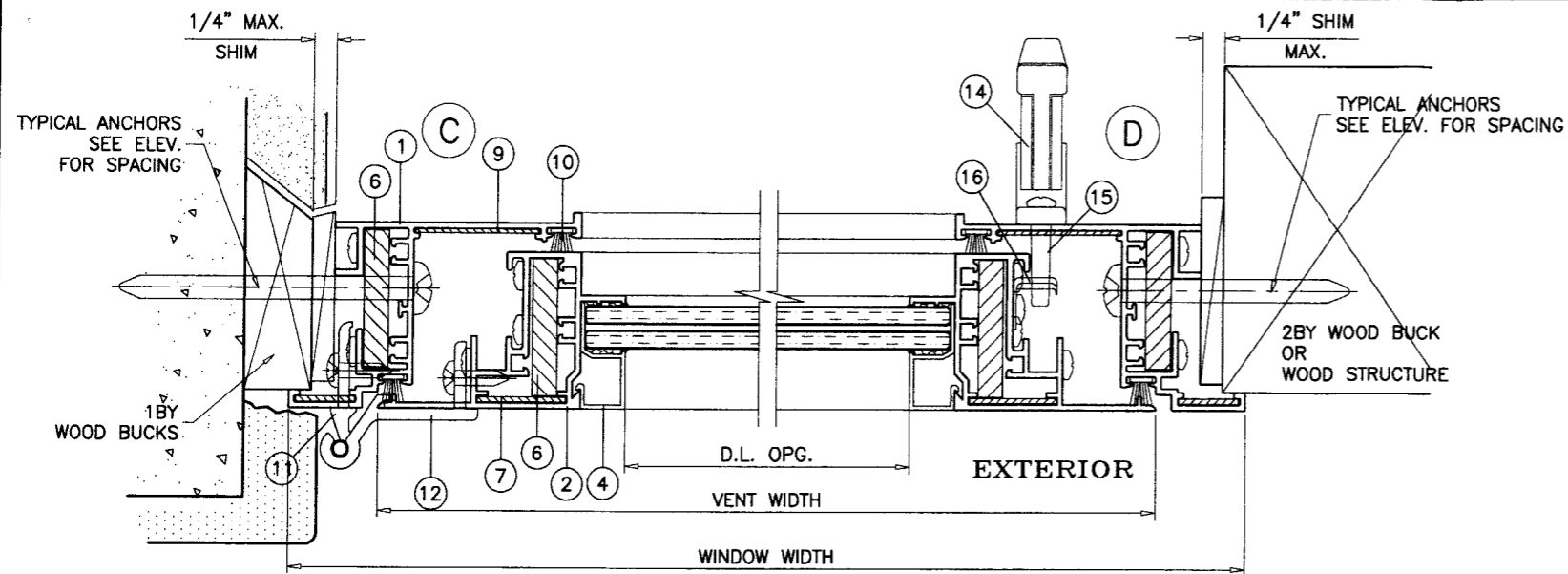

SINGLE VENT WINDOWS (BUTT HINGE OPTION)

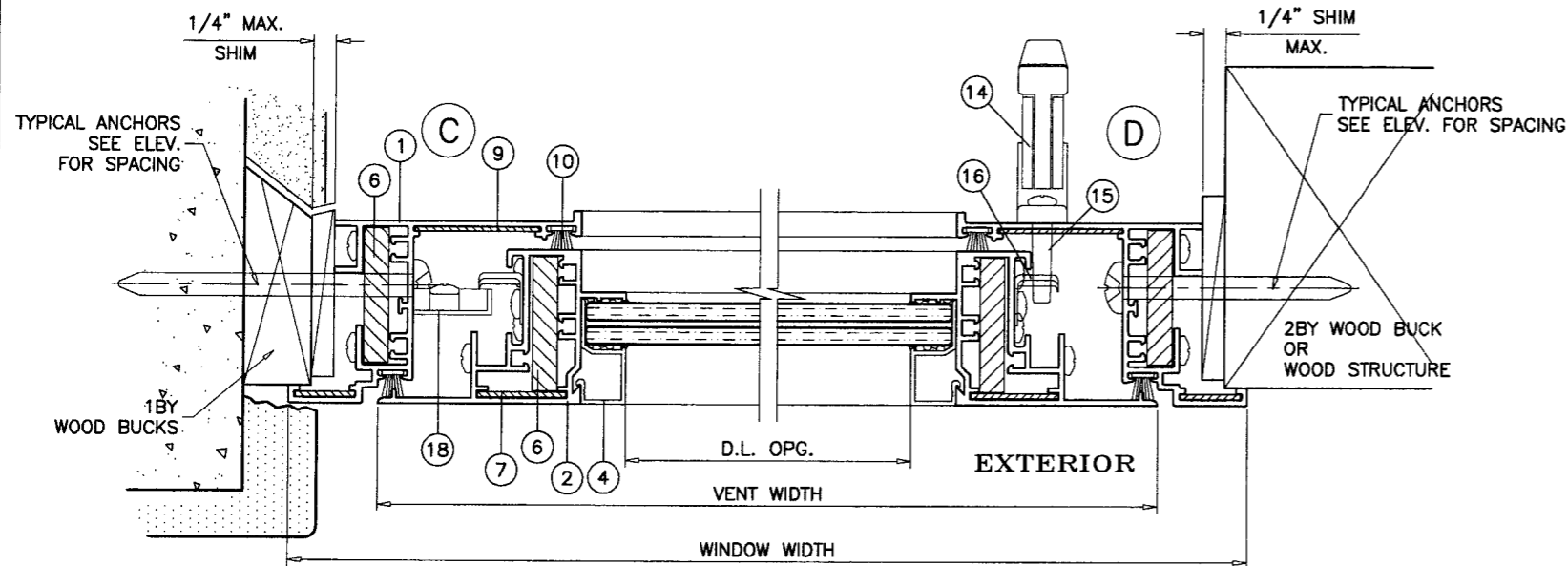

SINGLE VENT WINDOWS (CONCEALED HINGE OPTION)

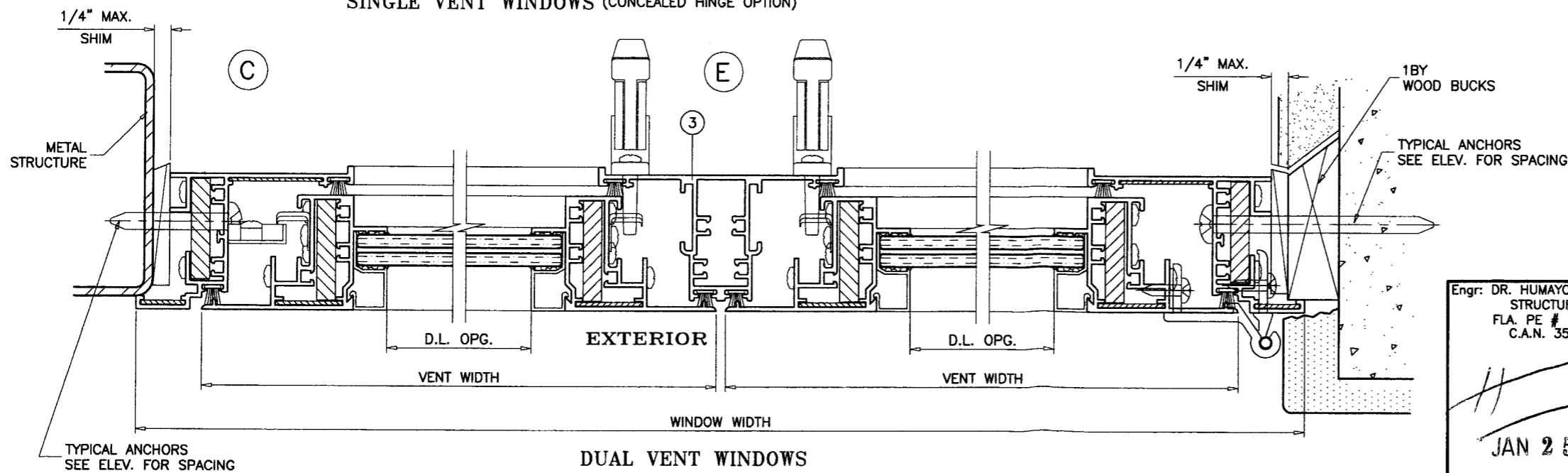
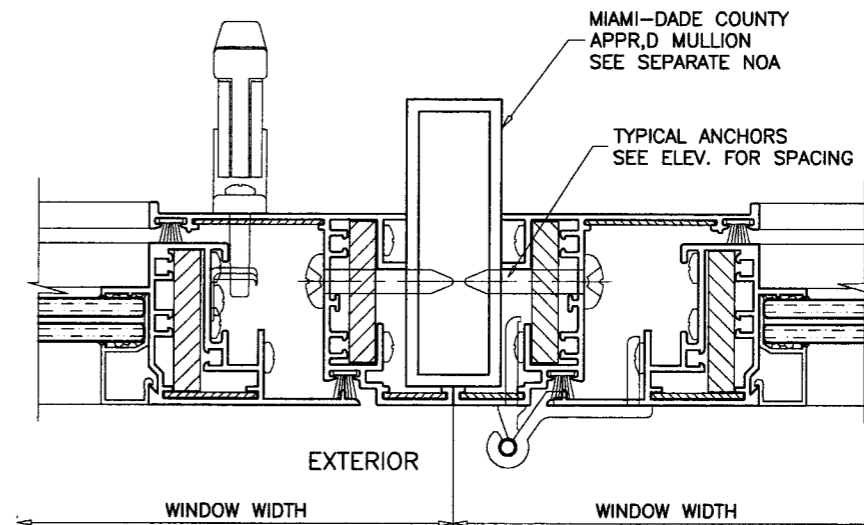

DUAL VENT WINDOWS

Engr: DR. HUMAYOON FAROOQ
STRUCTURES
FLA. PE # 16557
C.A.N. 3538

PRODUCT REVISED
as complying with the Florida
Building Code
Acceptance No. 08-0506-11
Expiration Date MAY 1, 2013
By *Manuel Perez*
Miami Dade Product Control
Division

JAN 25 2008

afc
AL-FAROOQ CORPORATION
ENGINEERS & PRODUCT DEVELOPMENT
1235 S.W. 87 AVE
MIAMI, FLORIDA 33174
TEL. (305) 264-8100 FAX (305) 262-6978
COMP-ANL\W06-30T.M.W.

SERIES 515 ALUMINUM CASEMENT WINDOW (L.M.I.)
TM WINDOW AND DOOR
601 N.W. 12TH AVE.
POMPANO BEACH, FL. 33069
TEL. (954) 781-4430 FAX. (954) 781-5078

revisions:	no	date	description
	A	10.11.06	REV. PER BCCO COMMENTS
	B	01.11.08	CLASS & HARDWARE OPTIONS ADD.

date: 04-14-06
scale: 1/2" = 1"
dr. by: HAMID
chk. by:

drawing no.
W06-30

sheet 5 of 7

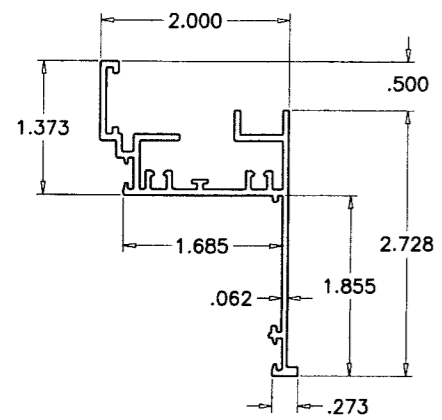

1 FRAME

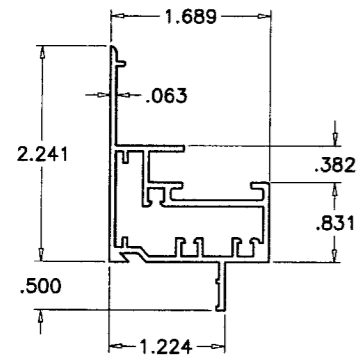

2 VENT

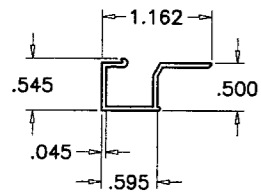

4 GLAZING BEAD

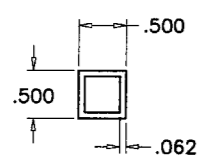

4A GLAZING TUBE

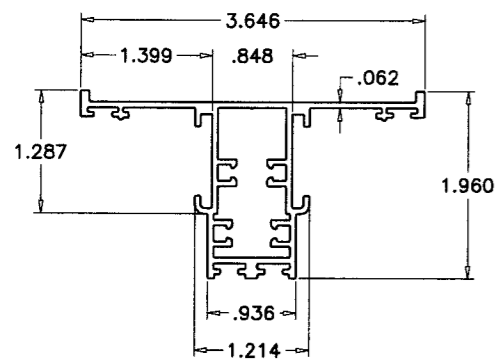

3 IMPOST

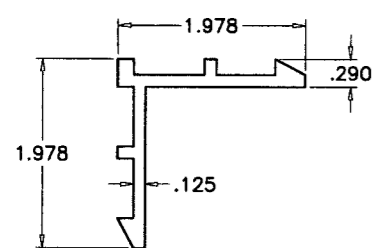

6 CORNER KEY

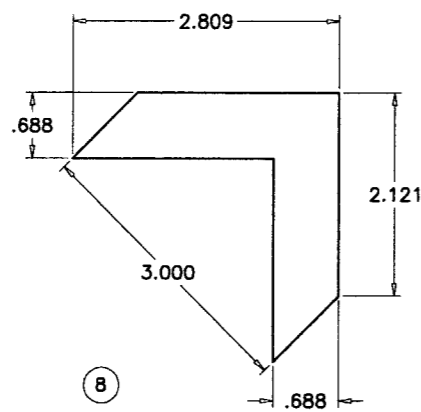

8

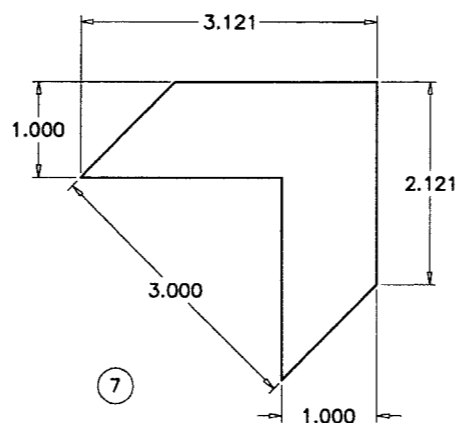

7

CORNER KEYS

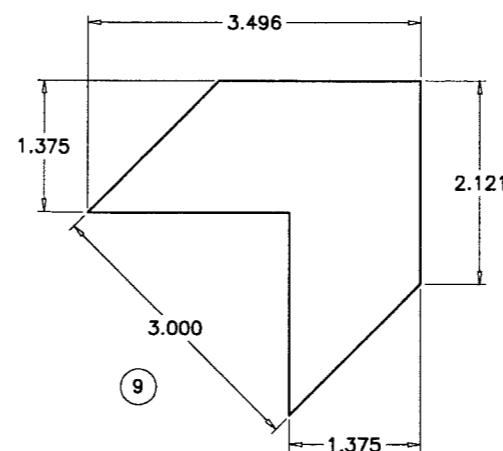

9

ITEM	PART #	QUANTITY	DESCRIPTION	MATERIAL	MANF./SUPPLIER/REMARKS
1	GW37528	4	FRAME	6063-T6	-
2	GW37526	4	VENT	6063-T6	-
3	GW37524	1	IMPOST	6063-T6	-
4	TM145	AS REQD.	GLAZING BEAD	6063-T6	-
4A	-	AS REQD.	GLAZING TUBE	6063-T6	-
5	#10 X 1-1/4"	2/ CORNER	FRAME/VENT ASSEMBLY SCREWS	ST. STEEL	PH SMS
6	SW27713	-	CORNER KEY	ALUMINUM	-
7	-	-	CORNER KEY (3 X 1 X .062" CHEVRON)	ALUMINUM	-
8	-	-	CORNER KEY (3 X 11/16 X .062" CHEVRON)	ALUMINUM	-
9	-	-	CORNER KEY (3 X 1-3/8" X .041" CHEVRON)	ALUMINUM	-
10	2230	AS REQD.	FRAME & VENT W'TRIPPING	FINSEAL	-
11	GW37521	AS REQD.	BUTT HINGE INTERIOR (FASTENED W/ (3) #10 X 3/8" PH SMS)	ALUMINUM	-
12	GW37522	AS REQD.	BUTT HINGE EXTERIOR (FASTENED W/ (2) #10 X 3/8" PH SMS)	ALUMINUM	-
13	23-65-32	-	ROTO OPERATOR (FASTENED W/ (4) #10 X 3/8" PH SMS)	-	TRUTH
14	24-11-32	AS REQD.	LEVER TYPE CAM LOCK (FASTENED W/ (2) #10 X 3/8" PH SMS)	-	-
15	21089	-	STRIKE KEEPER (FASTENED W/ (4) #8 X 1/2" TH SMS)	-	TRUTH
16	30238	AS REQD.	KEEPER (FASTENED W/ (2) #10 X 3/8" PH SMS)	-	-
17	300 SERIES	2/ VENT	3 BAR CONCEALED HINGE (FASTENED W/ (2) #10 X 3/8" PH SMS)	ST. STEEL	AT SASH TOP & BOTTOM
18	SB001/SB002	3/ VENT	4" LONG SNUBBER (FASTENED WITH (2) #8 X 1/2" HEX H SD SCREWS)	ZINC	AT HINGE RAIL
19	-	-	-	-	-

Engr. DR. HUMAYOUN FAROOQ
STRUCTURES
FLA. PE # 16557
C.A.N. 3538

JAN 25 2008

PRODUCT REVISED
as complying with the Florida
Building Code
Acceptance No. 08-0506.11
Expiration Date MAY 1, 2013
By *Mauro Perez*
Miami Dade Product Control
Division

af c
AL-FAROOQ CORPORATION
ENGINEERS & PRODUCT DEVELOPMENT
1235 S.W. 87 AVE
MIAMI, FLORIDA 33174
TEL. (305) 264-8100 FAX. (305) 262-6978
COMP-ANL\W06-30TMW

SERIES 515 ALUMINUM CASEMENT WINDOW (L.M.I.)
TM WINDOW AND DOOR
601 N.W. 12TH AVE.
POMPANO BEACH, FL. 33069
TEL. (954) 781-4430 FAX. (954) 781-5078

no.	date	by	description
A	10.11.06	REV. PER BCCO COMMENTS	
B	01.11.08	GLASS & HARDWARE OPTIONS ADD.	

date: 04-14-06
scale: 1/2" = 1"
dr. by: HAMID
chk. by:

drawing no.
W06-30
sheet 6 of 7

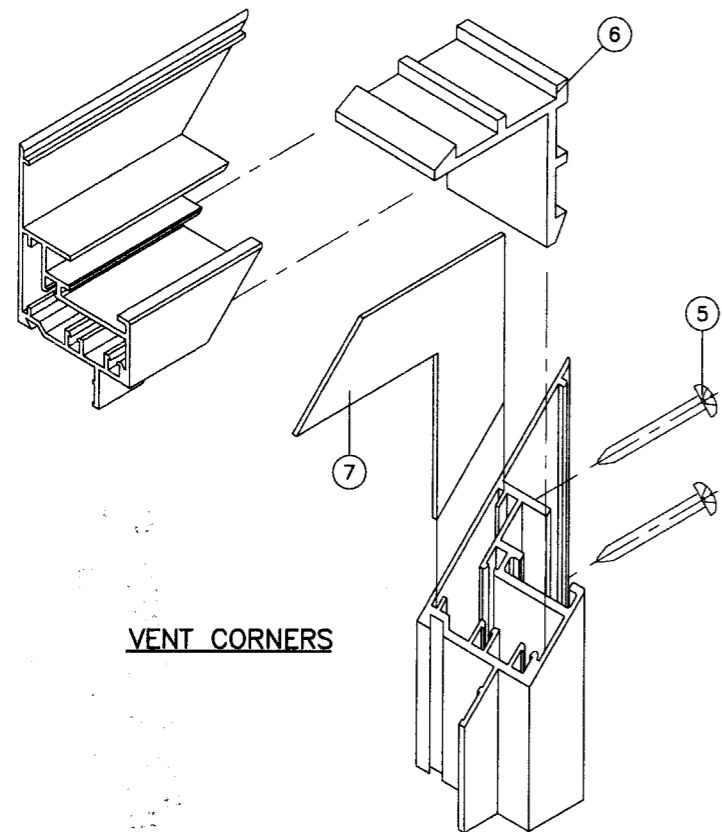

VENT CORNERS

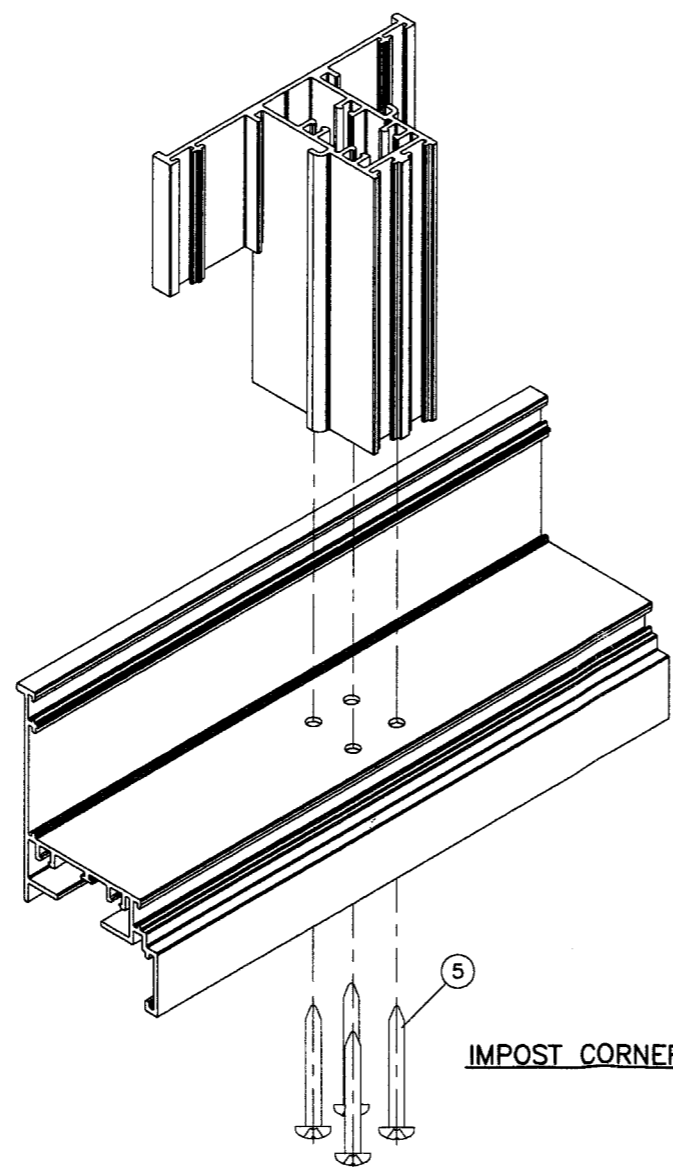

IMPOST CORNERS

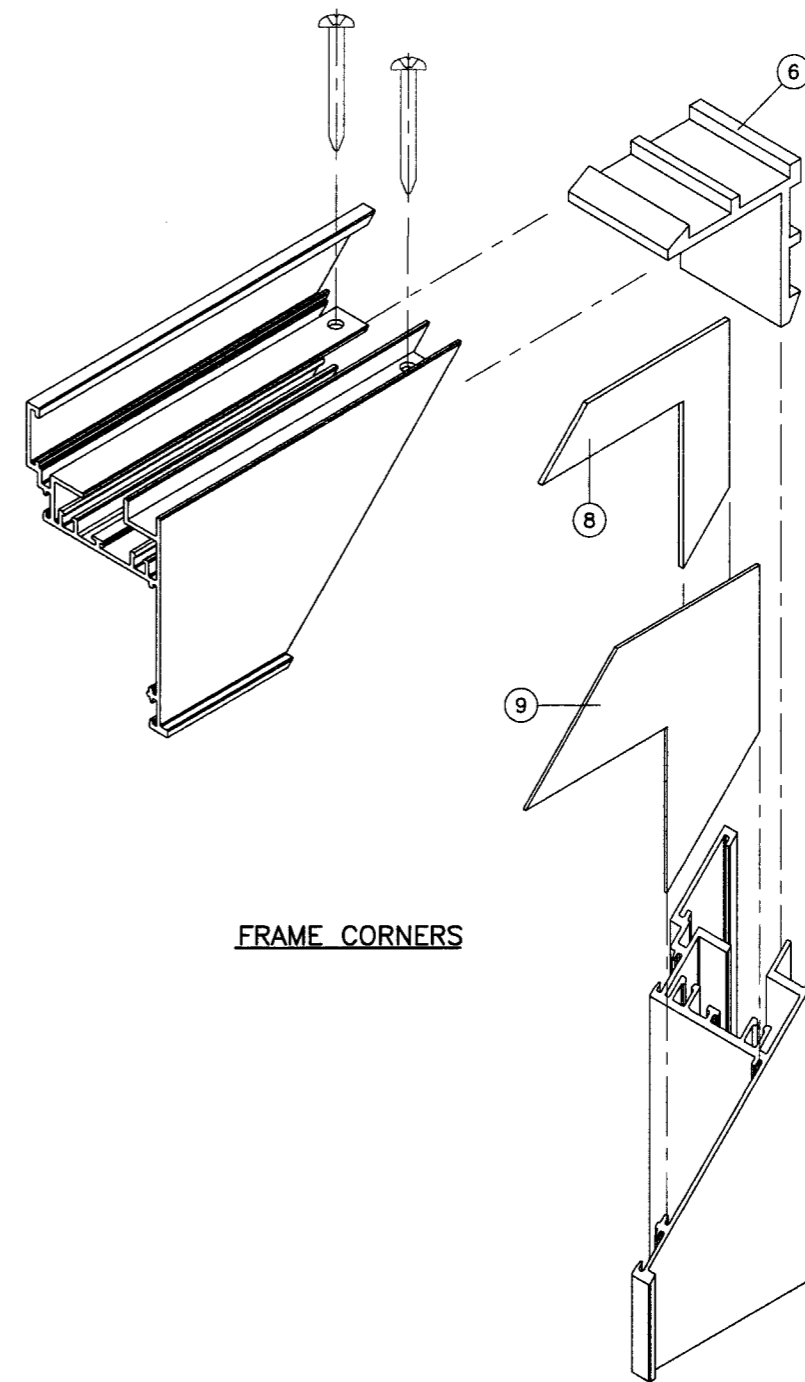

FRAME CORNERS

Engr: DR. HUMAYOON FAROOQ
STRUCTURES
FLA. PE # 16557
C.A.N. 3538

JAN 25 2008

PRODUCT REVISED
as complying with the Florida
Building Code
Acceptance No. *DB-0506.11*
Expiration Date *MAY 1, 2013*
By *Manuel Jerez*
Miami Dade Product Control
Division

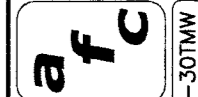

AL-FAROOQ CORPORATION
ENGINEERS & PRODUCT DEVELOPMENT
1235 S.W. 87 AVE
MIAMI, FLORIDA 33174
TEL. (305) 264-8100 FAX. (305) 262-6978

COMP-ANL\W06-30TAW

SERIES 515 ALUMINUM CASEMENT WINDOW (L.M.I.)

TM WINDOW AND DOOR
601 N.W. 12TH AVE.
POMPANO BEACH, FL. 33069

TEL. (954) 781-4430 FAX. (954) 781-5078

no	date	by	description
A	10.11.06	REV. PER BCCO COMMENTS	
B	01.11.08	GLASS & HARDWARE OPTIONS ADD.	

date: 04-14-06
scale: 1/2" = 1"
dr. by: HAMID
chk. by:

drawing no.
W06-30

sheet 7 of 7